

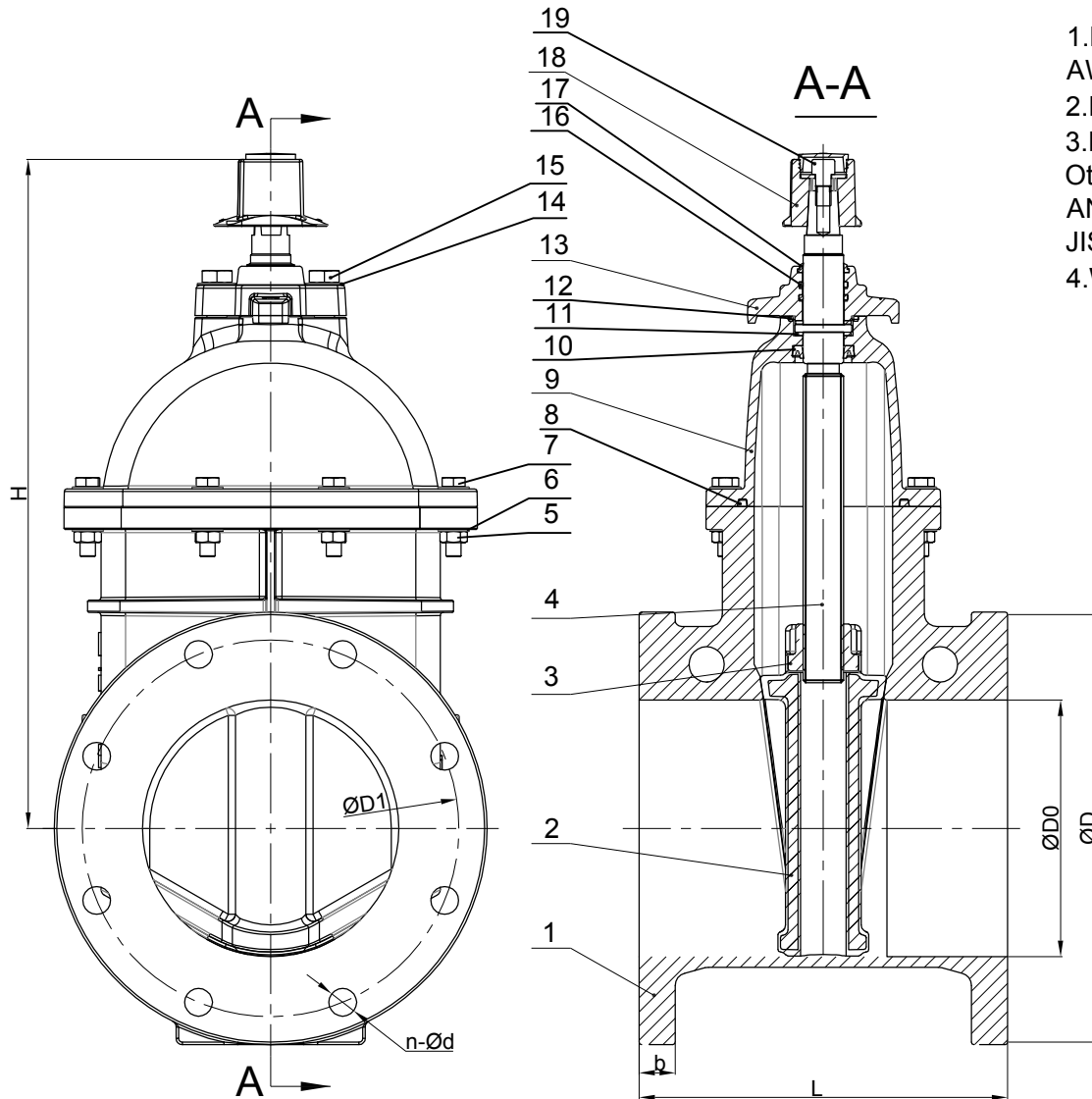

Size	L	ΦDo	ΦD	ANSI/ASME Class125&150		EN1092-2 PN10		EN1092-2 PN16		JIS10K		AS2129 Table D		AS2129 Table E		b	H
				ΦD1	n-Φd	ΦD1	n-Φd	ΦD1	n-Φd	ΦD1	n-Φd	ΦD1	n-Φd	ΦD1	n-Φd		
8"	292	Φ203	Φ343	Φ298.5	8-Φ22	Φ295	8-Φ23	Φ295	12-Φ23	Φ290	12-Φ23	Φ292	8-Φ18	Φ292	8-Φ22	28.6	540
10"	330	Φ254.6	Φ406	Φ362	12-Φ25	Φ350	12-Φ23	Φ355	12-Φ28	Φ355	12-Φ25	Φ356	8-Φ22	Φ356	12-Φ22	30.2	625
12"	356	Φ304.8	Φ483	Φ432	12-Φ25	Φ400	12-Φ23	Φ410	12-Φ28	Φ400	16-Φ25	Φ406	12-Φ22	Φ406	12-Φ26	31.8	700

*All dimensions are in millimeter.



- 1.Design Standard/设计标准: AWWA C515 for 2"-8"; AWWA C509 for 10"-12".
- 2.Face to Face Standard/结构长标准: ANSI B16.10
- 3.Flange Drilling/法兰钻孔: ANSI/ASME B16.1 Class125, Other flange types available upon request ANSI/ASME B16.1 Class 150, EN1092-1 PN10/PN16, JIS 10K/16K, AS 2129 Table D/Table E, BS10 Table D/Table E.
- 4.Working Pressure/工作压力: 175PSI, 200PSI, 250PSI, 300PSI.

19	Bolt/内六角螺栓	Galvanized steel/碳钢镀锌	A307 Q235-A
18	Cap/防尘圈	Ductile Iron/球铁	A536 65-45-12
17	Dust Guard/防尘圈	EPDM/三元乙丙橡胶	ASTM D2000
16	O-ring/O型圈	EPDM/三元乙丙橡胶	ASTM D2000
15	Bolt/六角头螺栓	Galvanized steel 10.9grade/碳钢镀锌 10.9级	A307 Q235-A
14	Washer/垫片	Galvanized steel/碳钢镀锌	A307 Q235-A
13	Gland/压盖	Ductile Iron/球铁	A536 65-45-12
12	O-ring/O型圈	EPDM/三元乙丙橡胶	ASTM D2000
11	Washer/垫片	Nylon/尼龙	Nylon
10	V-Ring/V型圈	EPDM/三元乙丙橡胶	ASTM D2000
9	Bonnet/阀盖	Ductile Iron/球铁	A536 65-45-12
8	Bonnet Gasket/中法兰密封垫	EPDM/三元乙丙橡胶	ASTM D2000
7	Bolt/六角头螺栓	Galvanized steel 10.9grade/碳钢镀锌 10.9级	A307 Q235-A
6	Washer/平垫圈	Galvanized steel/碳钢镀锌	A307 Q235-A
5	Nut/螺母	Galvanized steel/碳钢镀锌	A307 Q235-A
4	Stem/阀杆	Stainless Steel/不锈钢	ASTM A276 431/304/316
3	Stem Nut/阀杆螺母	Aluminium Bronze/铝青铜	AS1565 C95210
2	Wedge/闸板	Ductile Iron Encapsulated with EPDM//球铁+三元乙丙橡胶	A536 65-45-12+EPDM
1	Body/阀体	Ductile Iron/球铁	A536 65-45-12
No./序号	Name/名称	Material/材料	Specification/规范

DRN		WEIGHT		MATERIAL
CHK		SCALE		NRS Flange x Flange Gate Valve 8"-12"
APP		DATE		
				CZ0026
				Z3713BUF-FF-8-12-Assembly-UL
REV				20171115-A

This document is the property of Huihua Valve Industry Co. Distribution of this document without the written consent of the owner is strictly forbidden. Failure to comply will incur a liability for damages.

http://www.hiwa.cn Website sales@hiwa.cn Email

86 - 533 - 6077200 Phone 86 - 533 - 6077253 FAX

Huihua Valve Industry co.